

TRACTOR DUMP TRAILER 2PTS-6,5 finer rock carrier

This trailer is mainly used for transportation sand, gravel and finer rock as well as manure, sawdust, gravel, wood chips, compost, silage, grain, beetroots, on all types of roads and in the field. Transportation of bulk building materials is allowed, with the exception of rocks and cobblestones.

Side walls can be opened down and up by special locking system with manual handle in the lower part of the side walls. Each side wall consists of two parts divided by a b-pillar. The floor thickness is 4 mm.

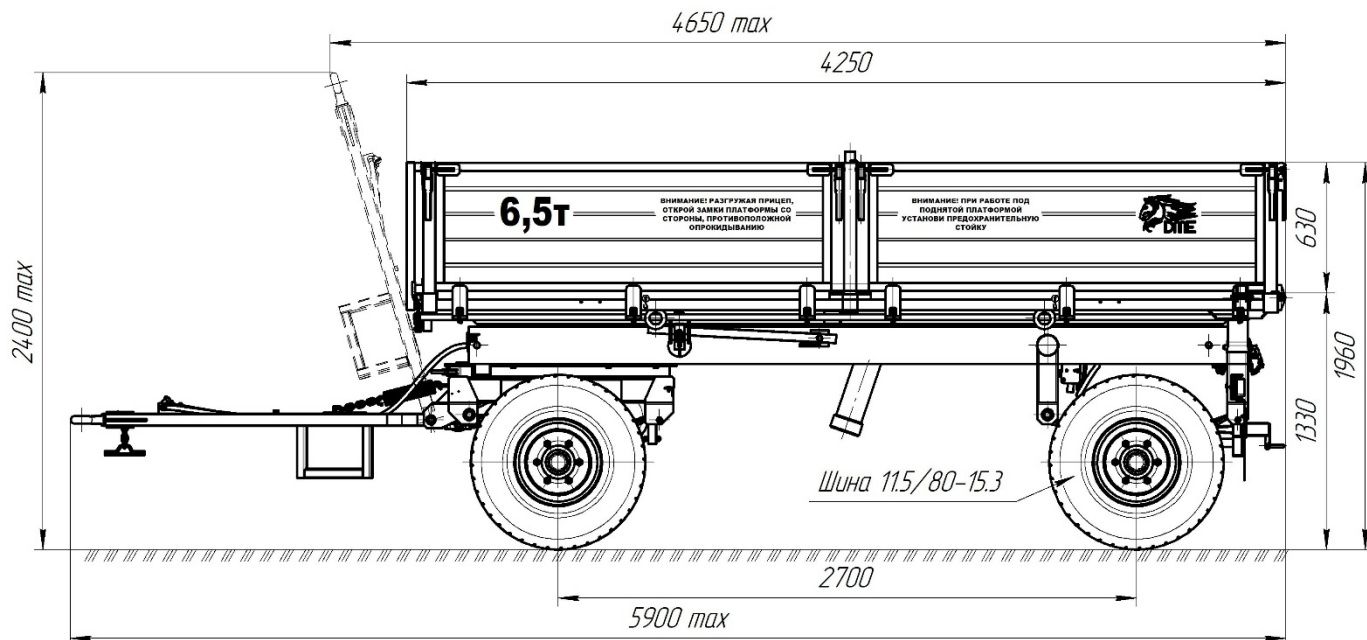

Technical characteristics

Parameter	Value
1 Type	Trailer
2 Tractor drawbar category	1,4-2
3 Trailer category	Ra3
4 Lifting capacity, kg, max	6 500
5 Max speed, km/h	
- transport mode	30
- working mode	18
6 Axle number, pcs.	2
7 Wheels per axle, pcs.	2
8 Wheel base, mm, min	2 700
9 Unloading sides	3
10 Tires / pressure, MPa	
- basic	11.5/80-15.3 PR14 / 0,475
- option 1	12.5/80-15.3 PR14 / 0,43
11 - option 2	
Weight, kg, max	1 930
- design gross weight (without options with basic tires)	8 480

12	Weight distribution per axle, kg, max - axle Nr. 1 - axle Nr. 2	4 410 4 070
13	Overall dimensions, mm, max - length - width - height - with basic tires - with optional tires 1	5 900 2 310 1 960 1 985
14	Track width, mm, min	1 850
15	Inner body dimensions, mm, max - length - width	4 050 2 130
16	Sides height, mm, max	630
17	Body floor surface, m ² , max	8,63
18	Body volume, m ³ , max	5,43
19	Ground clearance, mm, min	310
20	Body floor loading height with basic tires, mm, max	1 330
21	Body tipping angle, degrees, min	45
22	Body tipping time, s, max	50
23	Hydraulic system working pressure, MPa, max	20
24	Manning level, persons	1
25	Working brake system - brake axle number - brake mechanism type - brake activation type - brake system scheme	2 drum pneumatic single line (dual line on request)
26	Parking brake system	mechanical with manual drive
27	Lifetime, years, min	8

