

## TRACTOR DUMP TRAILERS 2PTS-5

The trailer is designed to transport various agricultural goods on all types of roads and in the field. Transportation of bulk building materials is allowed, with the exception of rocks and cobblestones.

Trailers are available in following configurations:

- 2PTS-5 – basic trailer,
- 2PTS-5N – with full metal put-on sides,
- 2PTS-5S – with mesh put-on sides,
- 2PTS-5T – with tarp on frame,
- 2PTS-5NT – with full metal put-on sides and tarp on frame.

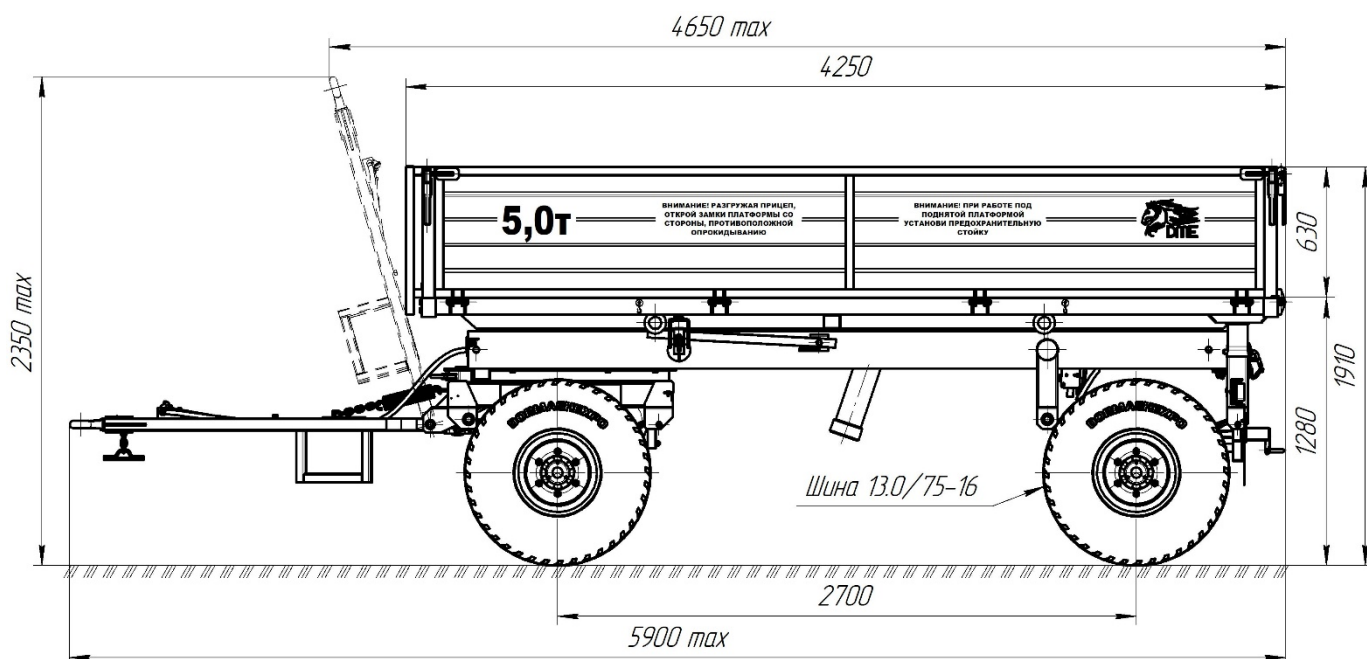

### Technical characteristics

Parameter	Value
1 Type	Прицепной
2 Tractor drawbar category	1,4-2
3 Trailer category	Ra3
4 Lifting capacity, kg, max	5 000
5 Max speed, km/h	
- transport mode	30
- working mode	18
6 Axle number, pcs.	2
7 Wheels per axle, pcs.	2
8 Wheel base, mm, min	2 700
9 Unloading sides	3
10 Tires / pressure, MPa	
- basic	13.0/75-16 PR8 / 0,24
- option 1	13.0/75-16 PR14 / 0,37
- option 2	10.0/75-15.3 PR14 / 0,55

11	Track width, mm, min - with basic tires - with optional tires 1 - with optional tires 2	1 930 1 930 1 850
12	Inner body dimensions, mm, max - length - width	4 050 2 130
13	Sides height, mm, max - main - full metal put-on - mesh put on	630 630 1 000
14	Body floor surface, m <sup>2</sup> , max	8,63
15	Body volume, m <sup>3</sup> , max - with main sides - with full metal put-on sides - with mesh put on sides	5,43 10,87 14,06
16	Ground clearance, mm, min	310
17	Body floor loading height with basic tires, mm, max	1280
18	Body tipping angle, degrees, min	45
19	Body tipping time, s, max	50
20	Hydraulic system working pressure, MPa, max	20
21	Manning level, persons	1
22	Working brake system - brake axle number - brake mechanism type - brake activation type - brake system scheme	1 drum pneumatic single line
23	Parking brake system	mechanical with manual drive
24	Lifetime, years, min	8

### Weights and overall dimensions

Trailer configuration	Weight, kg, max		Weight distribution per axle, kg, max		Overall dimensions, mm, max				
	design gross weight (without options with basic tires)	full weight (technical permissible)	Axle Nr. 1	Axle Nr. 2	Length	Width	Height		
							Basic tires	Optional tires 1	Optional tires 2
2PTS-5	1850	6920	3530	3390	5900	2310	1910	1910	1840
2PTS-5N	2040	7110	3630	3480			2540	2540	2470
2PTS-5S	2020	7090	3620	3470			2910	2910	2840
2PTS-5T	1960	7030	3590	3440			2140	2140	2070
2PTS-5NT	2150	7220	3680	3540			2770	2770	2700